



# Specification

Revised 2019/04/08

## Liqualloy™ Power Inductor GLUHK Series

### Features

- 2.0mm×1.6mm square and 1.0mm max height
- Under surface terminal
- Liqualloy™ ; Super low core loss material for high switching frequency DC/DC converter
- Excellent low heat generating characteristics due to low DCR
- Metal composite structure (compact and high current capability)
- RoHS compliant.
- Halogen Free.

### Application

- For use in DC/DC converter in portable device  
(Smartphone , Tablet PC , SSD , HDD , DSC , Game etc.)

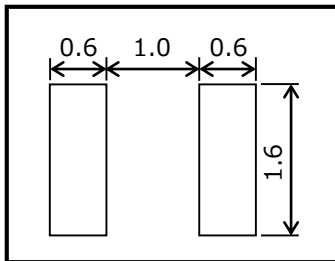

Recommended pattern

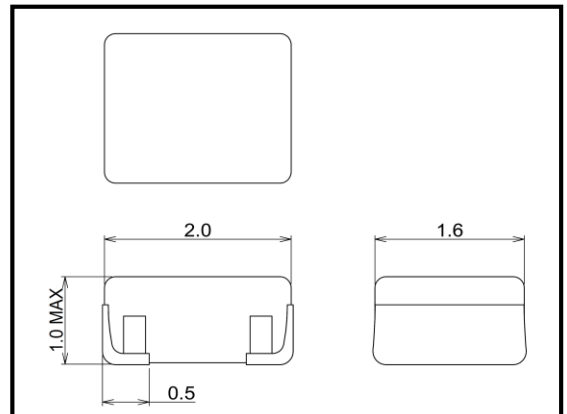
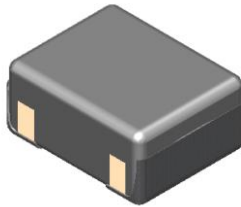

Unit: mm

- Operating Temperature : -40 to +125 [°C]  
( Including self temperature rise )
- Withstand DC Voltage : 20[V]
- Operating Voltage : 16[V]

Part No.	Inductance at 1MHz ( $\mu$ H) $\pm 20\%$	DC Resistance (m $\Omega$ ) Max. (Typ.)	Saturation Current Idc1(A) Max.(Typ.)	Heat Rating Current Idc2(A) Max. (Typ.)
GLUHKR4701A	0.47	30 ( 25 )	3.0 ( 3.6 )	3.6 ( 4.3 )
GLUHK1R001A	1.0	58 ( 48 )	2.2 ( 2.8 )	2.4 ( 2.9 )
GLUHK1R501A	1.5	89 ( 74 )	1.8 ( 2.3 )	1.9 ( 2.3 )
GLUHK2R201A	2.2	126 ( 105 )	1.5 ( 1.9 )	1.7 ( 2.0 )
GLUHK4R701A	4.7	266 ( 222 )	1.0 ( 1.3 )	1.1 ( 1.4 )

- ACR=Rs-DCR (Rs:equivalent series resistance)
- The saturation current (Idc1) is the DC current value having inductance decrease down to 30%.  
(at 20°C)
- The heat rating current (Idc2) is the DC current value having temperature increase up to 40°C.  
(at 20°C)

# Typical Inductance & Q vs. Frequency

Revised 2019/04/08

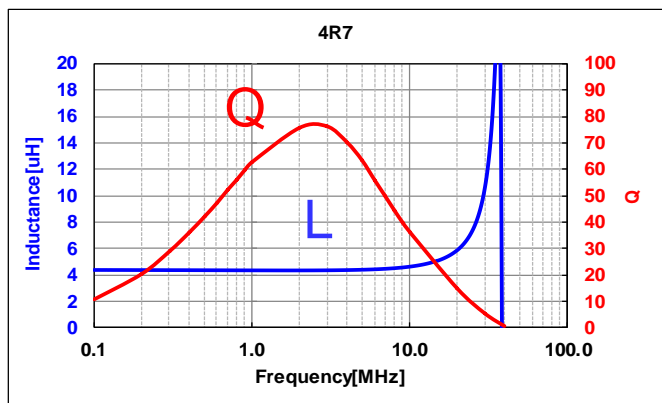
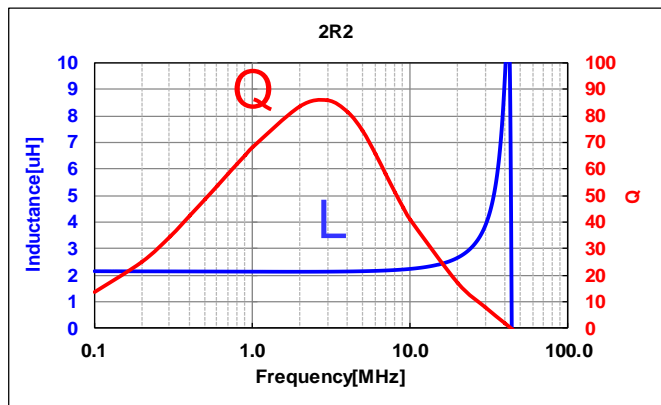
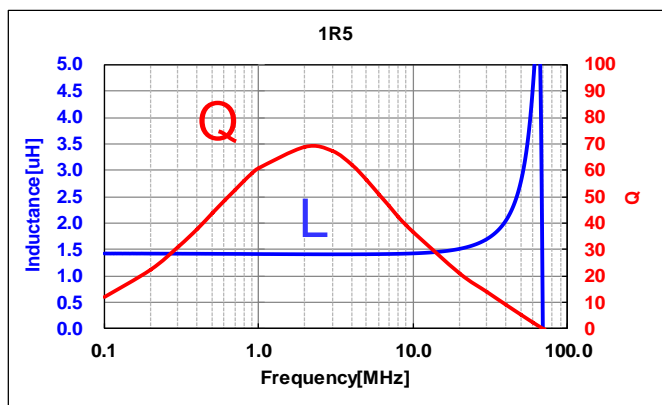
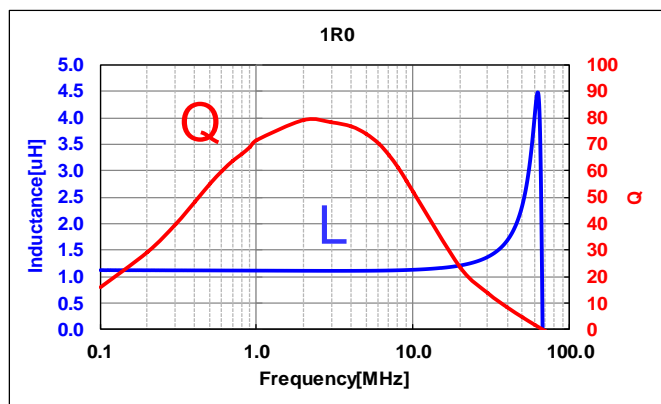
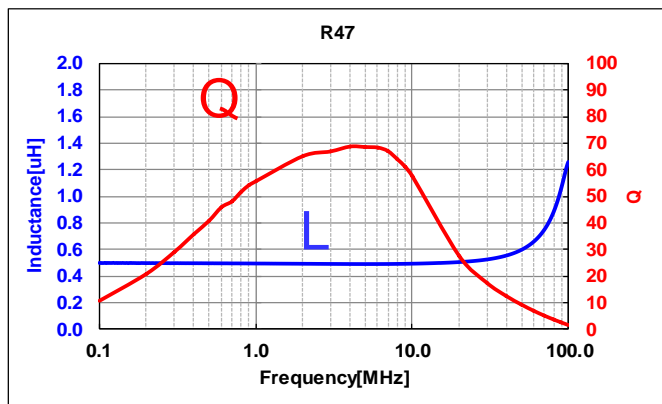

# Typical Inductance & $\Delta$ Temperature vs. Load Current

Revised 2019/04/08

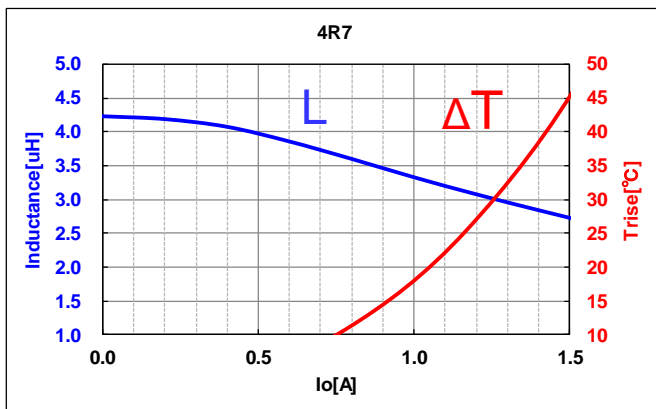
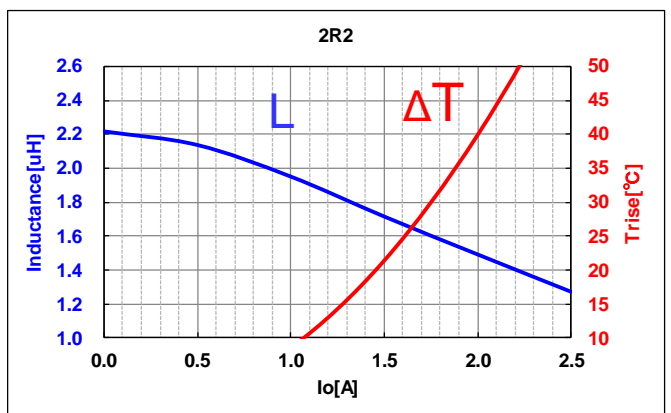
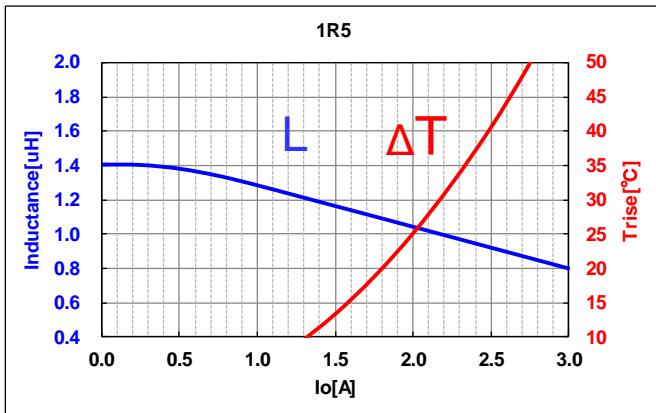
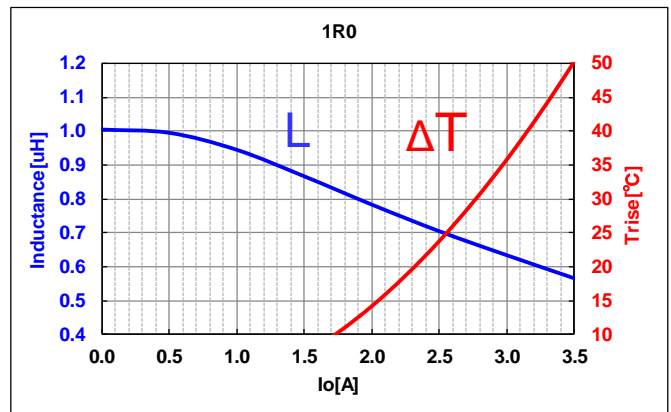
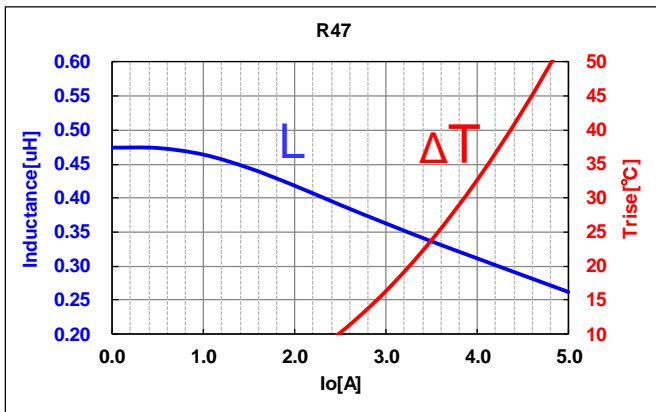

# Typical ACR vs. Frequency

Revised 2019/04/08

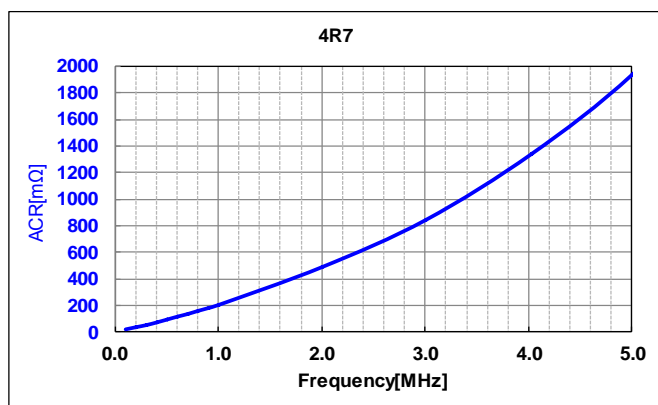
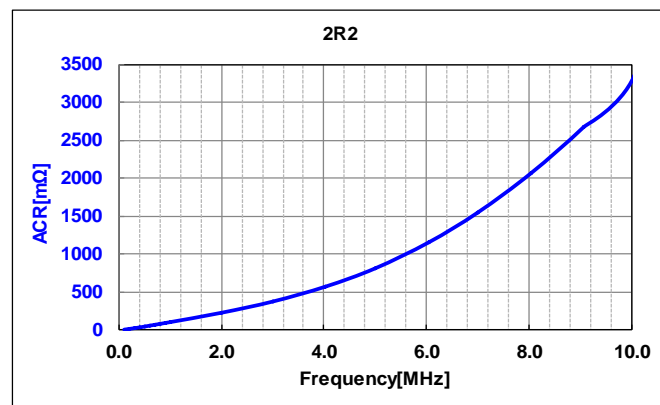
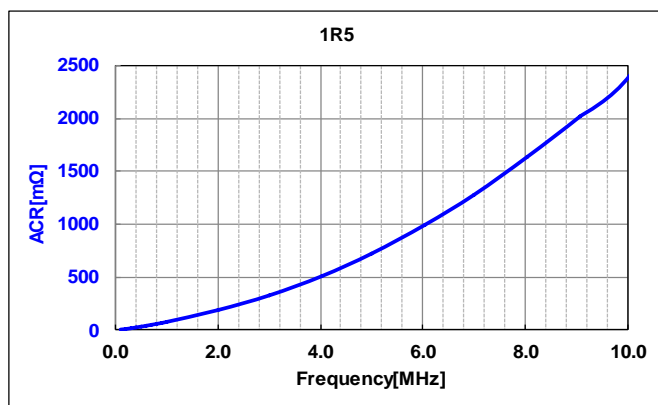
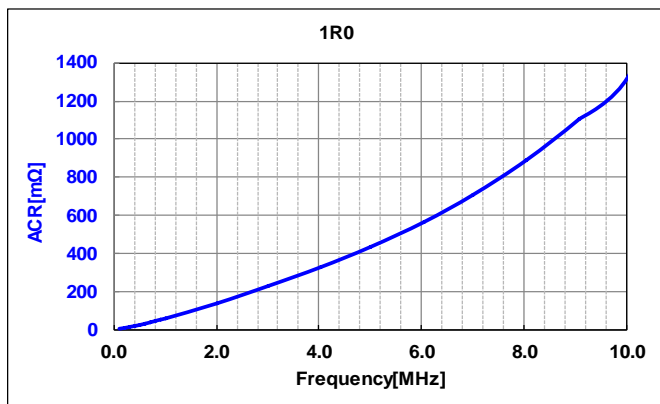
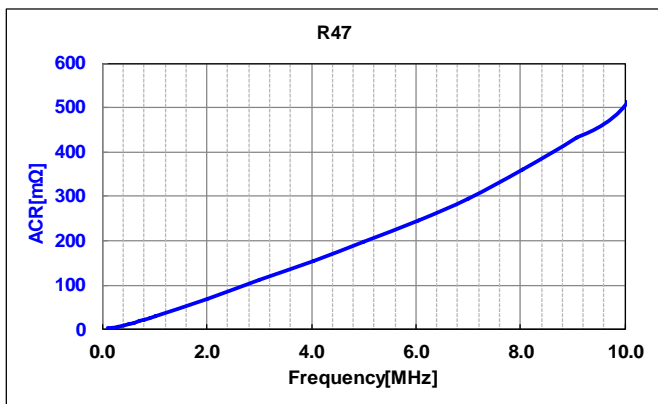

# Attention

Revised 2019/04/08

## Precautions when handling our products

1. For the export of products which are controlled items subject to foreign and domestic export laws and regulations, you must obtain approval and/or follow the formalities of such laws and regulations.
2. Products must not be used for military and/or antisocial purposes such as terrorism, and shall not be supplied to any party intending to use the products for such purposes.
3. Unless provided for otherwise, the products have been designed and manufactured for application in equipment and devices which are sold to end users in the market, including audio-visual (AV) equipment, electrical home appliances, office machines, information and communication equipment, and amusement equipment. The products are not intended for use in, and must not be used for, any application for nuclear equipment, driving equipment for aerospace or any other unauthorized use. With the exception of the abovementioned prohibited applications, please contact an Alps Alpine sales representative and/or evaluate the total system regarding applicability for applications involving high levels of safety and liability such as medical equipment, burglar alarm equipment, disaster prevention equipment and undersea equipment. Please also incorporate fail-safe design, protection and redundant circuitry, malfunction protection, and/or fire protection into the complete system to ensure safety and reliability of the total system.
4. Before using products which were not specifically designed for use in automotive applications, please contact an Alps Alpine sales representative.

## Cautions for using this technical data sheet

1. The specifications herein are an overview of the specifications. Obtain official specifications before use.
2. The colors of the products this technical data sheet may slightly differ from those of the actual products.
3. The external appearance, functions and other specifications herein may be discontinued without prior notice.

## Inquiries about this product

Products Information Center  
+81 (3) 5499-8154  
Products Information Site  
[Http://www.alps.com/products/e/](http://www.alps.com/products/e/)

## **ALPSALPINE CO., LTD.**

1-7, Yukigaya-otsukamachi, Ota-ku, Tokyo, Japan 145-8501



# Specification

Revised 2019/01/31

## Liqualloy™ Power Inductor GLULK Series

### Features

- 2.5mm × 2.0mm square and 1.0mm max height
- Under surface terminal
- Liqualloy™ ; Super low core loss material for high switching frequency DC/DC converter
- Excellent low heat generating characteristics due to low DCR
- Metal composite structure (compact and high current capability)
- RoHS compliant.
- Halogen Free.

### Application

- For use in DC/DC converter in portable device  
(Smartphone , Tablet PC , SSD , HDD , DSC , Game etc.)

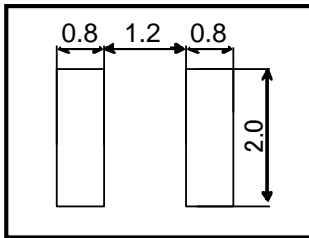

Recommended pattern

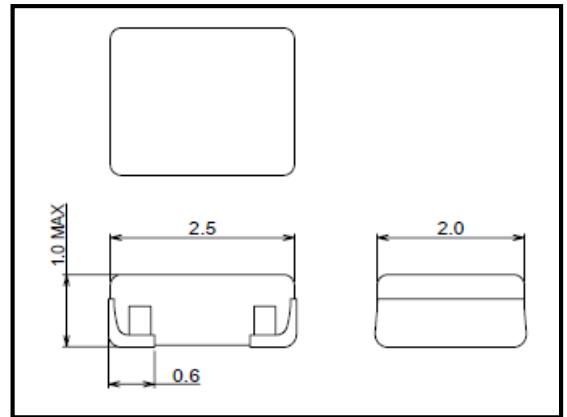
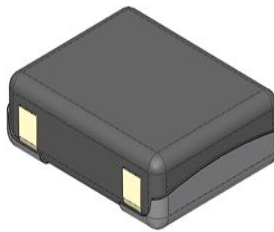

Unit: mm

- Operating Temperature: -40 to +125 [°C]  
( Including self temperature rise )
- Withstand DC Voltage : 20[V]
- Operating Voltage : 16[V]

Part No.	Inductance at 1MHz ( $\mu$ H) $\pm 20\%$	DC Resistance (m $\Omega$ ) Max. (Typ.)	AC Resistance at 1MHz (m $\Omega$ ) Typ	Saturation Current Idc1 (A) Max.(Typ.)	Heat Rating Current Idc2 (A) Max. (Typ.)
GLULKR4701A	0.47	24 ( 20 )	22	3.6 ( 4.5 )	3.9 ( 4.9 )
GLULK1R001A	1.0	48 ( 40 )	58	2.4 ( 3.1 )	2.6 ( 3.3 )
GLULK1R501A	1.5	70 ( 58 )	79	2.1 ( 2.7 )	2.2 ( 2.8 )
GLULK2R201A	2.2	102 ( 85 )	111	1.8 ( 2.3 )	1.7 ( 2.2 )
GLULK4R701A	4.7	192 ( 160 )	196	1.2 ( 1.6 )	1.3 ( 1.7 )

- ACR=Rs-DCR (Rs:equivalent series resistance)
- The saturation current (Idc1) is the DC current value having inductance decrease down to 30%.  
(at 20°C)
- The heat rating current (Idc2) is the DC current value having temperature increase up to 40°C.  
(at 20°C)

# Typical Inductance & Q vs. Frequency

Revised 2019/01/31

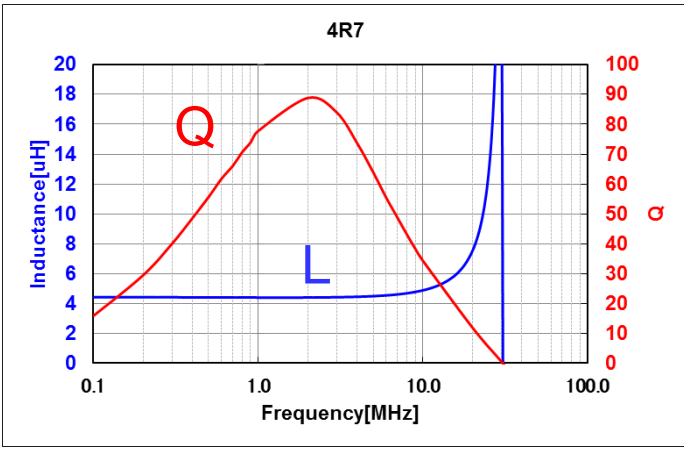
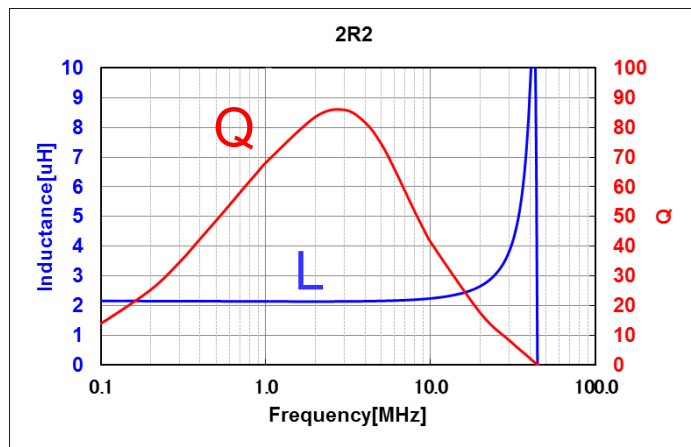
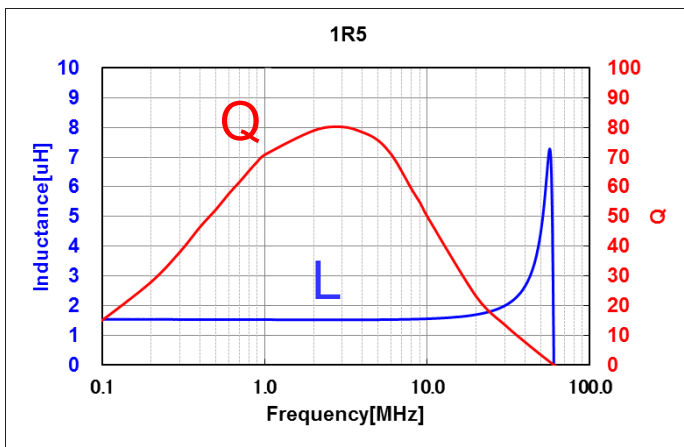
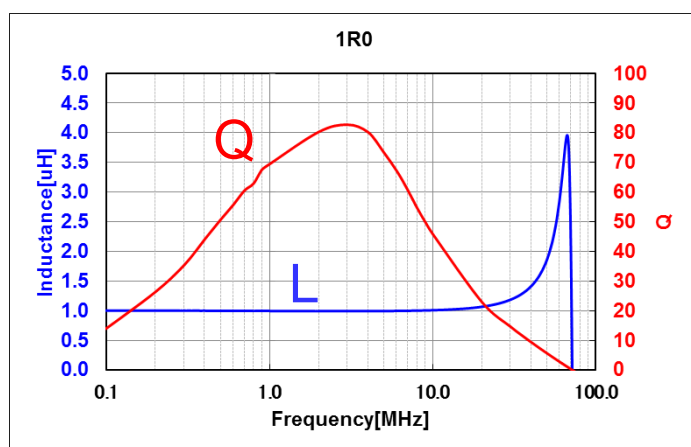
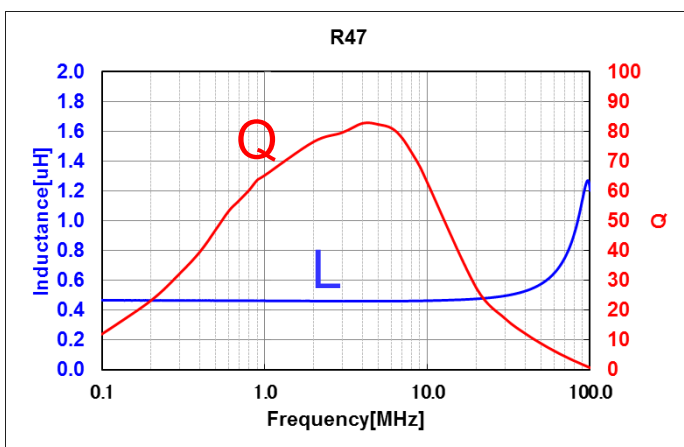

# Typical Inductance & $\Delta$ Temperature vs. Load Current

Revised 2019/01/31

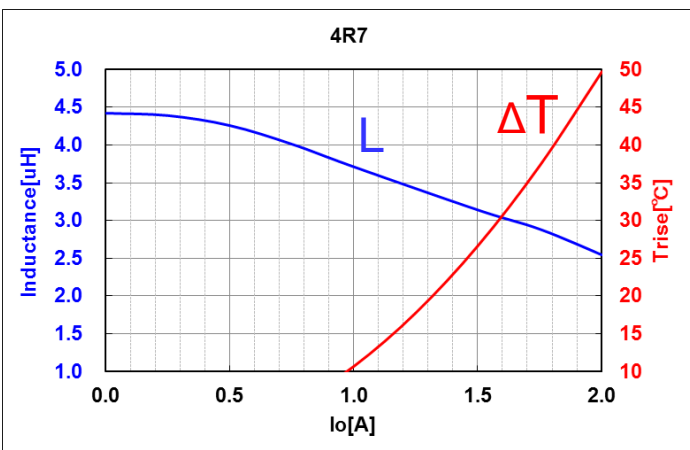
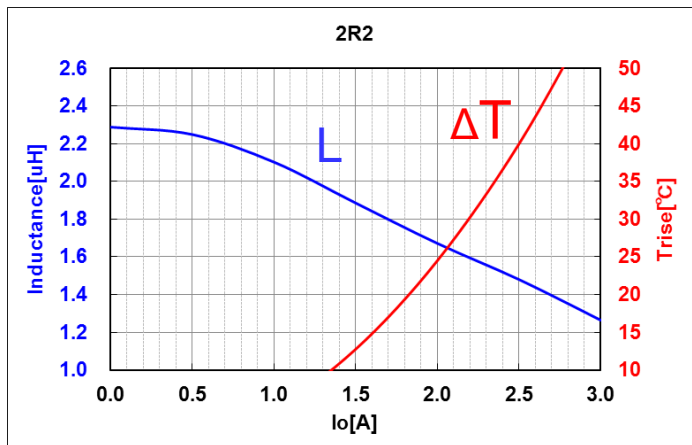
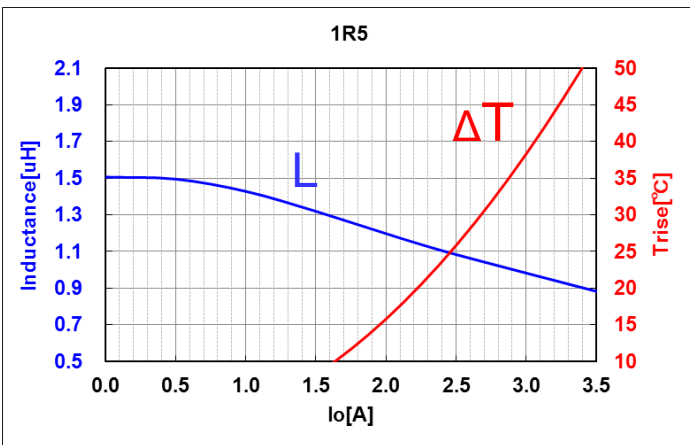
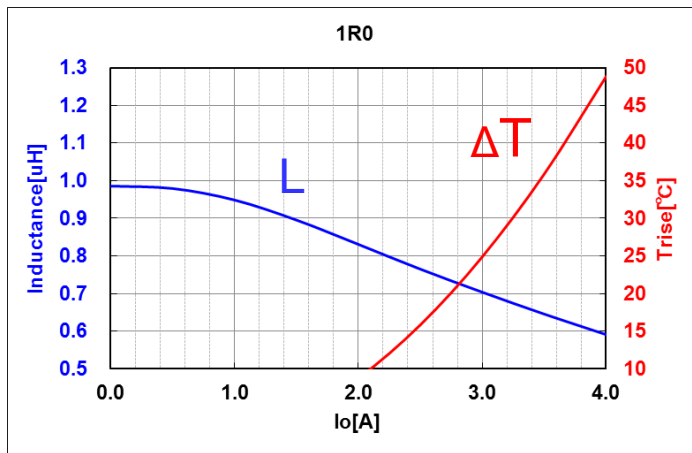
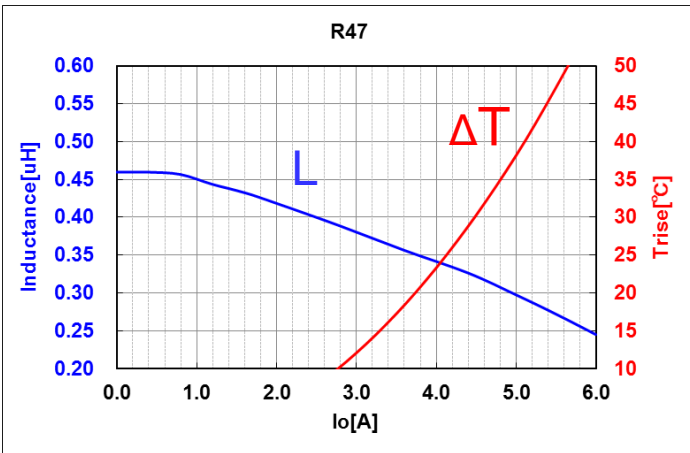

# Typical ACR vs. Frequency

Revised 2019/01/31

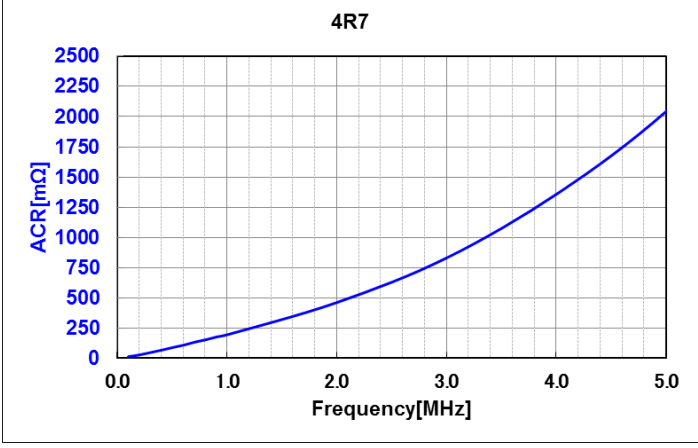
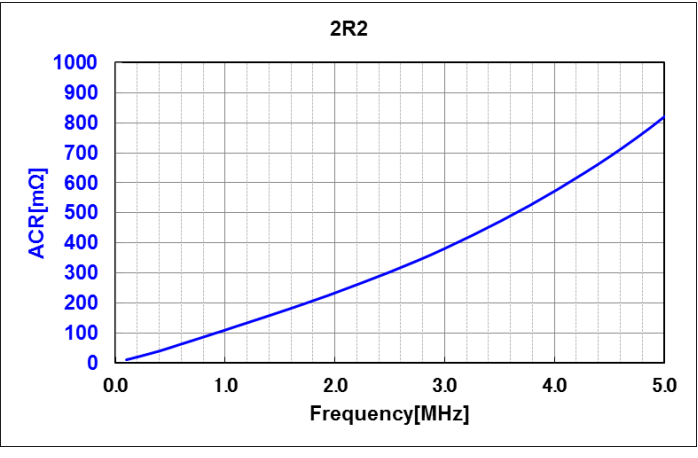
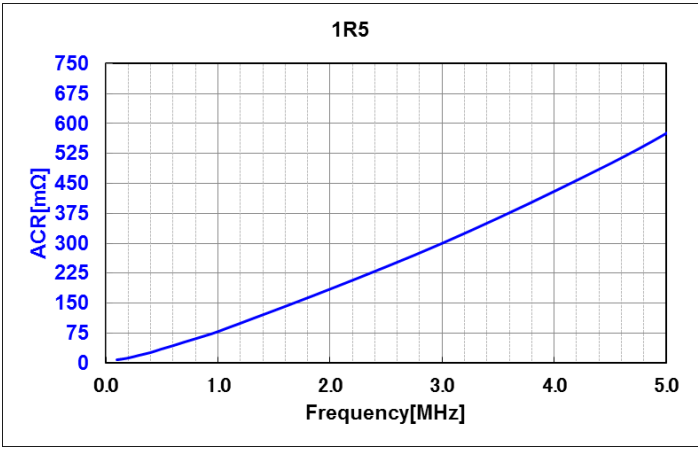
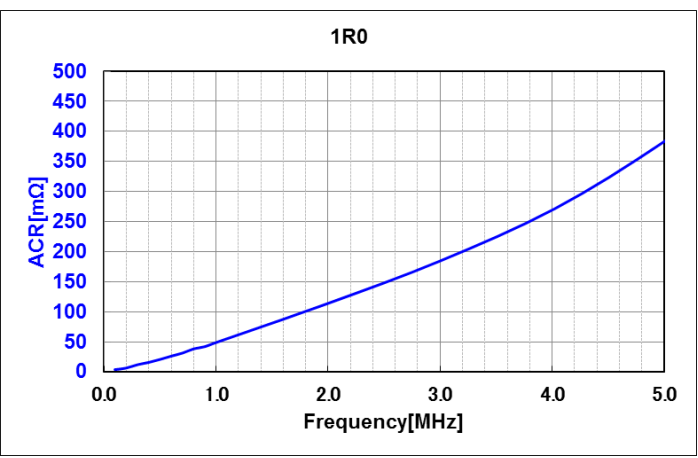
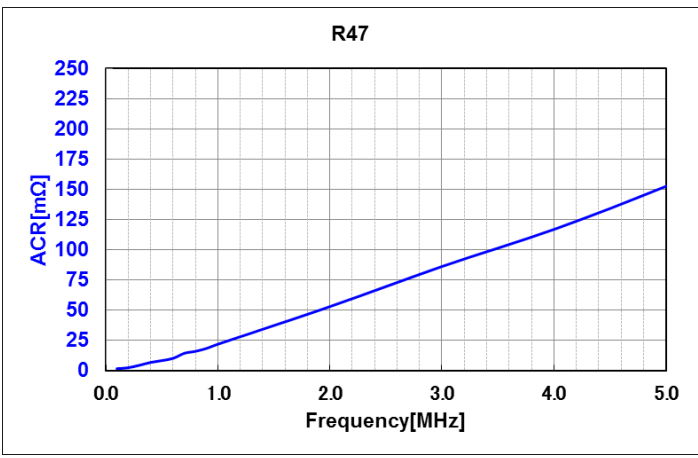

# Attention

Revised 2019/01/31

## Precautions when handling our products

1. For the export of products which are controlled items subject to foreign and domestic export laws and regulations, you must obtain approval and/or follow the formalities of such laws and regulations.
2. Products must not be used for military and/or antisocial purposes such as terrorism, and shall not be supplied to any party intending to use the products for such purposes.
3. Unless provided for otherwise, the products have been designed and manufactured for application in equipment and devices which are sold to end users in the market, including audio-visual (AV) equipment, electrical home appliances, office machines, information and communication equipment, and amusement equipment. The products are not intended for use in, and must not be used for, any application for nuclear equipment, driving equipment for aerospace or any other unauthorized use. With the exception of the abovementioned prohibited applications, please contact an Alps Alpine sales representative and/or evaluate the total system regarding applicability for applications involving high levels of safety and liability such as medical equipment, burglar alarm equipment, disaster prevention equipment and undersea equipment. Please also incorporate fail-safe design, protection and redundant circuitry, malfunction protection, and/or fire protection into the complete system to ensure safety and reliability of the total system.
4. Before using products which were not specifically designed for use in automotive applications, please contact an Alps Alpine sales representative.

## Cautions for using this technical data sheet

1. The specifications herein are an overview of the specifications. Obtain official specifications before use.
2. The colors of the products this technical data sheet may slightly differ from those of the actual products.
3. The external appearance, functions and other specifications herein may be discontinued without prior notice.

## Inquiries about this product

Products Information Center  
+81 (3) 5499-8154  
Products Information Site  
[Http://www.alps.com/products/e/](http://www.alps.com/products/e/)

**ALPSALPINE CO., LTD.**

1-7, Yukigaya-otsukamachi, Ota-ku, Tokyo, Japan 145-8501



# Specification

Revised 2019/06/27

## Liqualloy™ Power Inductor GLULM Series

### Features

- 2.5mmX2.0mm square and 1.2mm max height
- Under surface terminal
- Liqualloy™ ; Super low core loss material for high switching frequency DC/DC converter
- Excellent low heat generating characteristics due to low DCR
- Metal composite structure (compact and high current capability)
- RoHS compliant.
- Halogen Free.

### Application

- For use in DC/DC converter in portable device  
(Smartphone , Tablet PC , SSD , HDD , DSC , Game etc.)

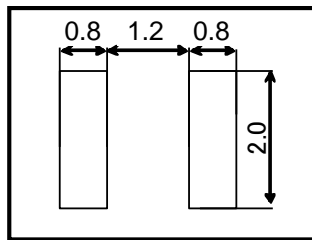

Recommended pattern

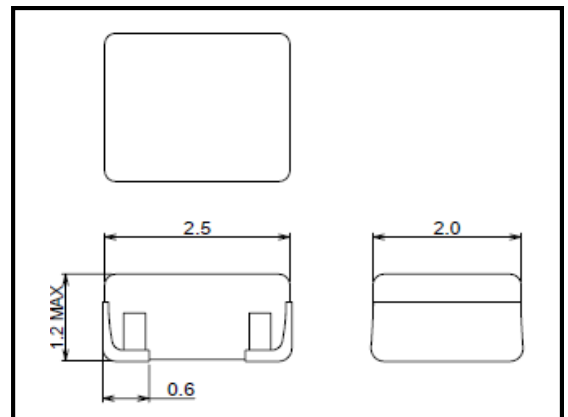
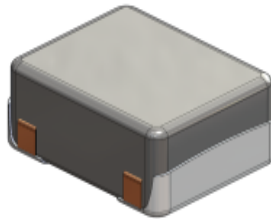

Unit: mm

- Operating Temperature: -40 to +125 [°C]  
( Including self temperature rise )
- Withstand DC Voltage : 20[V]
- Operating Voltage : 16[V]

Part No.	Inductance at 1MHz ( $\mu\text{H}$ ) $\pm 20\%$	DC Resistance ( $\text{m}\Omega$ ) Max. (Typ.)	Idc1: Saturation Current $\Delta L/L=30\%$ (A) Max. (Typ.)	Idc2: Heat Rating Current $\Delta T=40^\circ\text{C}$ (A) Max. (Typ.)
GLULMR2201A	0.22	11 ( 9 )	5.2 ( 6.5 )	5.5 ( 7.0 )
GLULM2R201A	2.2	82 ( 68 )	2.2 ( 2.7 )	2.3 ( 2.9 )
GLULM4R701A	4.7	186 ( 155 )	1.5 ( 1.9 )	1.4 ( 1.8 )

- $ACR=Rs-DCR$  ( $Rs$ :equivalent series resistance)
- The saturation current (Idc1) is the DC current value having inductance decrease down to 30%.  
(at 20°C)
- The heat rating current (Idc2) is the DC current value having temperature increase up to 40°C.  
(at 20°C)

# Typical Inductance & Q vs. Frequency

Revised 2019/06/27

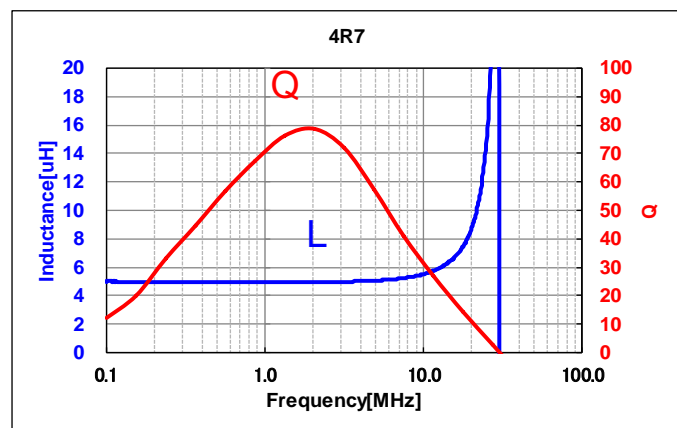
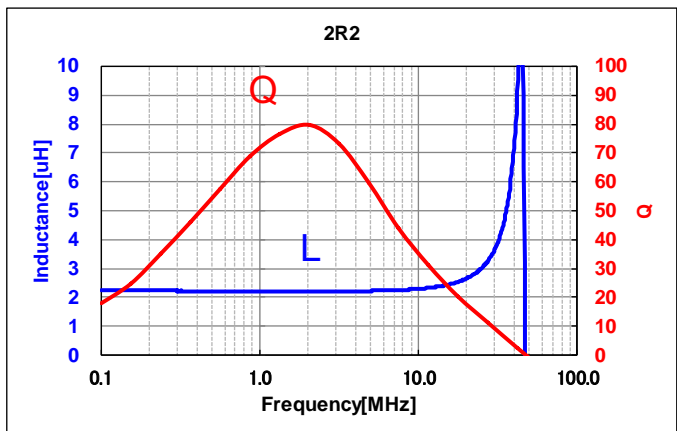
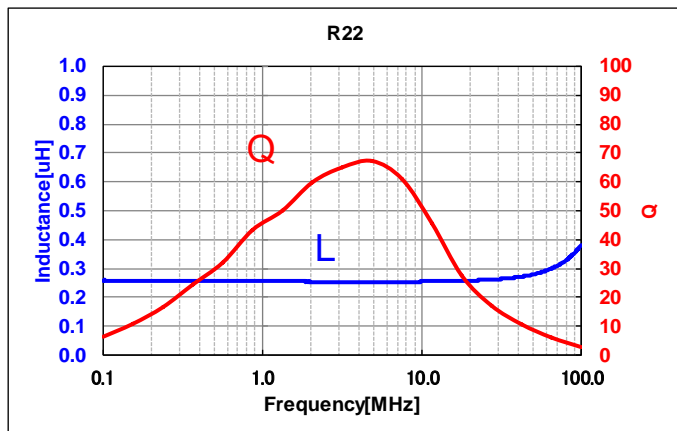

# Typical Inductance & $\Delta$ Temperature vs. Load Current

Revised 2019/06/27

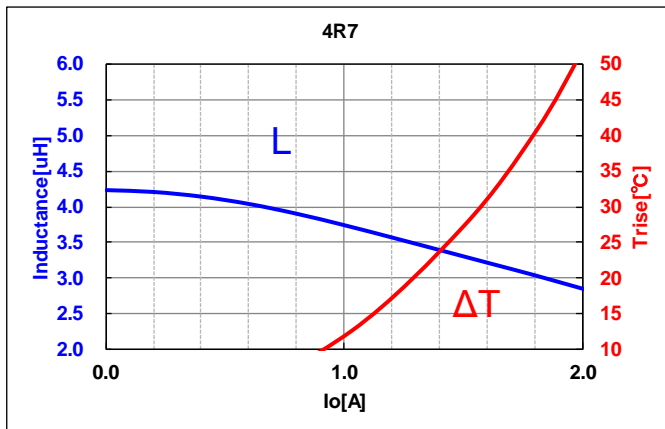
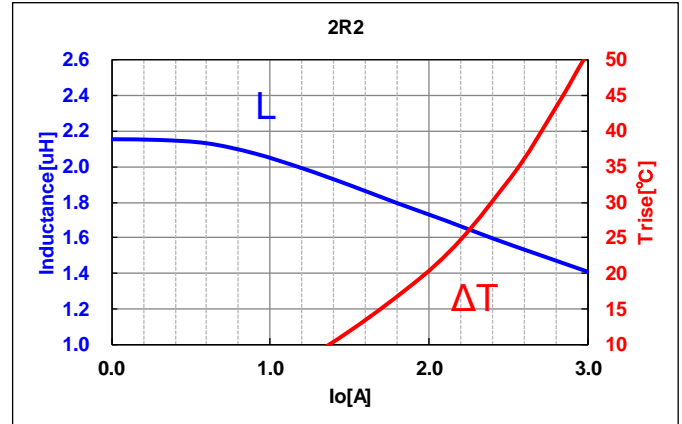
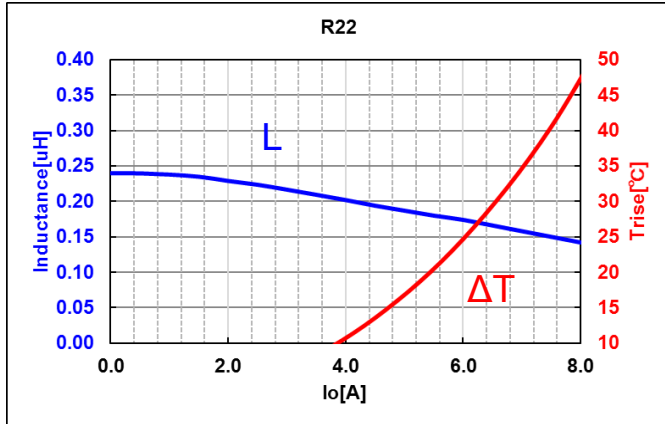

# Typical ACR vs. Frequency

Revised 2019/06/27

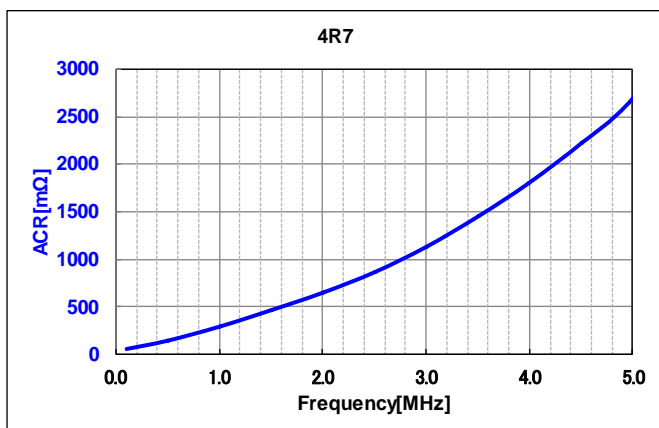
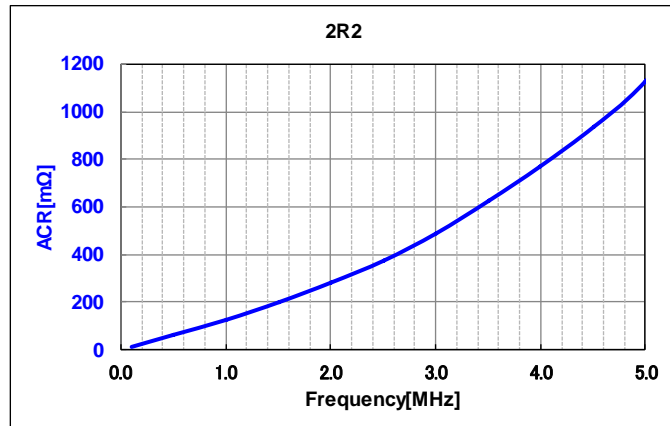
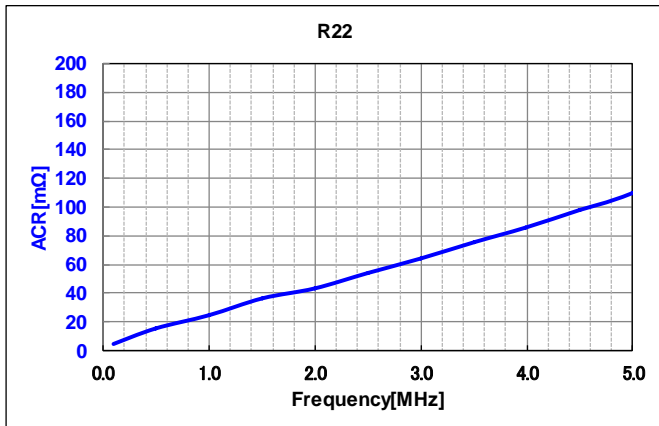

# Attention

Revised 2019/06/27

## Precautions when handling our products

1. For the export of products which are controlled items subject to foreign and domestic export laws and regulations, you must obtain approval and/or follow the formalities of such laws and regulations.
2. Products must not be used for military and/or antisocial purposes such as terrorism, and shall not be supplied to any party intending to use the products for such purposes.
3. Unless provided for otherwise, the products have been designed and manufactured for application in equipment and devices which are sold to end users in the market, including audio-visual (AV) equipment, electrical home appliances, office machines, information and communication equipment, and amusement equipment. The products are not intended for use in, and must not be used for, any application for nuclear equipment, driving equipment for aerospace or any other unauthorized use. With the exception of the abovementioned prohibited applications, please contact an Alps Alpine sales representative and/or evaluate the total system regarding applicability for applications involving high levels of safety and liability such as medical equipment, burglar alarm equipment, disaster prevention equipment and undersea equipment. Please also incorporate fail-safe design, protection and redundant circuitry, malfunction protection, and/or fire protection into the complete system to ensure safety and reliability of the total system.
4. Before using products which were not specifically designed for use in automotive applications, please contact an Alps Alpine sales representative.

## Cautions for using this technical data sheet

1. The specifications herein are an overview of the specifications. Obtain official specifications before use.
2. The colors of the products this technical data sheet may slightly differ from those of the actual products.
3. The external appearance, functions and other specifications herein may be discontinued without prior notice.

## Inquiries about this product

Products Information Center  
+81 (3) 5499-8154  
Products Information Site  
[Http://www.alps.com/products/e/](http://www.alps.com/products/e/)

## **ALPSALPINE CO., LTD.**

1-7, Yukigaya-otsukamachi, Ota-ku, Tokyo, Japan 145-8501